

Exam 1 Preparation Ch 1, 2, & 4 v01

There will be twenty questions chosen from below.

No Book/No Notes/No Phone/No Ipod/Yes Calculator /55 minutes

Name _____

$$4) y = x^2$$

Solve the problem.

- 1) Some values for a relation are given in the table. Is the relation a function?

x	y
1	2
2	5
3	8
3	11
4	14

$$5) x = y^4$$

$$6) x = y^2$$

- 2) Some values for a relation are given in the table. Is the relation a function?

x	y
5	3
6	4
7	6
8	6
9	15

$$7) 4x + 4y - 6 = 6 + 4(y - 1)$$

$$8) 3x + 5y - 5 = 5 + 5(y - 1)$$

Determine whether the relation is a function.

- 3) $y = 3x + 1$

Evaluate the function at the given value of x.

9) $f(x) = 4x + 6$, $f(-4)$

10) $f(x) = \frac{x - 7}{4x + 15}$, $f(-4)$

For the given function, find the value of x that corresponds to the given value of f(x).

11) $f(x) = 3x - 5$, $f(x) = -15.8$

12) $f(x) = -4x + 1$, $f(x) = -15.8$

13) $f(x) = 4x + 1$, $f(x) = -20.6$

14) $f(x) = -2x + 4$, $f(x) = -8.4$

Solve the problem.

15) David recently switched to a long distance phone company which charges a monthly fee of \$4.95 plus \$0.05 per minute. Find a linear function $f(m)$ that expresses the monthly bill as a function of minutes used m .

16) David recently switched to a long distance phone company which charges a monthly fee of \$5.95 plus \$0.07 per minute. Find a linear function $f(m)$ that expresses the monthly bill as a function of minutes used m .

17) A company has just purchased a new computer for \$5400. The company chooses to depreciate the computer using the straight-line method over 6 years. A linear function that expresses the book value of the computer as a function of its age x is $f(x) = -900x + 5400$. What is the book value of the computer after 2 years?

Simplify the expression without using a calculator.

18) -6^4

$$19) -3^{-2}$$

$$25) x^2y^{-4}$$

$$20) \frac{4^3}{4^4}$$

$$26) (3p^2)(-4p^4)$$

$$21) \frac{1}{3^{-2}}$$

$$27) (-5x^3y^{-4})(3x^{-1}y)$$

$$22) \frac{1}{3^{-4}}$$

$$28) (35x^3y^4)^{-1}(5x^2y)^4$$

$$29) (4x^{-8}y^9z^{-6})^{-3}$$

Simplify the expression.

$$23) x(x^4)$$

$$30) \frac{12a^{12}b^{-5}}{3a^9b^{-10}}$$

$$24) x^8x^7$$

$$31) \frac{3^{-8}x^{-2}y^4}{3^{-5}x^{-5}y^8}$$

Write the number in standard decimal form.

$$36) 3.66 \times 10^6$$

$$32) \frac{9x^{-5}y^{-3}z^4}{3xy^{-3}z^{-4}}$$

$$37) 3.15 \times 10^6$$

$$33) \left(\frac{4x^{-2}y^2}{12x^{-4}y^{-1}} \right)^3$$

$$38) 9.629 \times 10^{-5}$$

$$39) 9.919 \times 10^{-5}$$

Evaluate as specified.

$$34) \text{ For } f(x) = 32^x, \text{ find } f\left(\frac{7}{5}\right).$$

Write the number in scientific notation.

$$40) 6972$$

$$35) \text{ For } g(x) = 5^x, \text{ find } g(n+3).$$

$$41) 0.00005111$$

Simplify the expression. Assume that all variables are positive.

42) $x^{5/8} x^{3/8}$

43) $x^{-1/5} x^{-5/6}$

44) $(x^{1/4})^{-4}$

45) $(x^{-1/3})^{-1/2}$

46) $\frac{40x^{3/4}}{5x^{1/3}}$

47) $\frac{b^{2/3}c^{1/4}}{b^{-1/3}c^{-3/4}}$

48) $\frac{(4x^{1/7})^3}{x^{2/7}}$

49) $\frac{x^{-1/2}y^{3/8}}{(x^4y^{-5})^{-1/2}}$

50) $\frac{(216b^{-5}c^{12})^{1/3}}{(128b^{35}c^3)^{3/7}}$

51) $\left(\frac{2^3x^{1/5}y^4}{x^{1/5}}\right)^{1/3}$

Sketch the graph of the given function.

52) $y = 4^x$

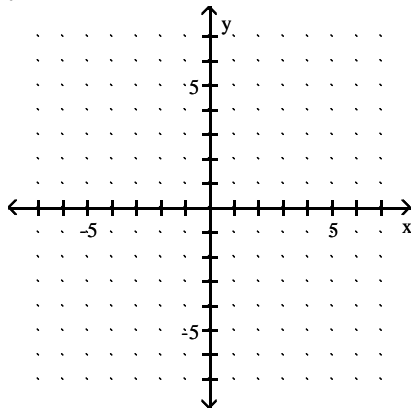

54) $f(x) = 30\left(\frac{1}{5}\right)^x$

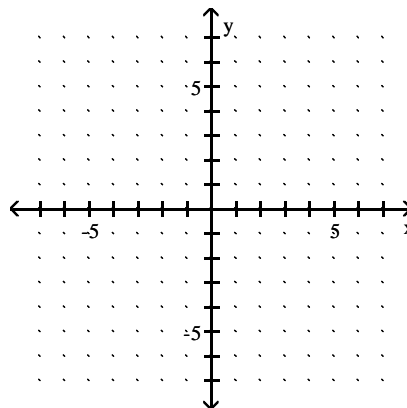

53) $f(x) = 4(3)^x$

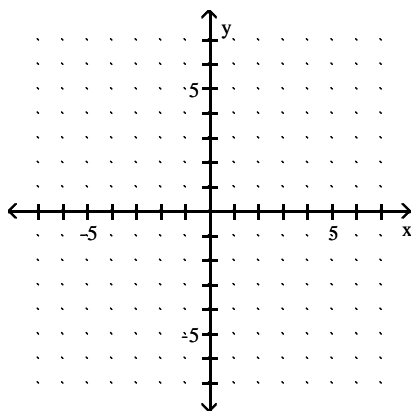

55) $f(x) = 12\left(\frac{2}{3}\right)^x$

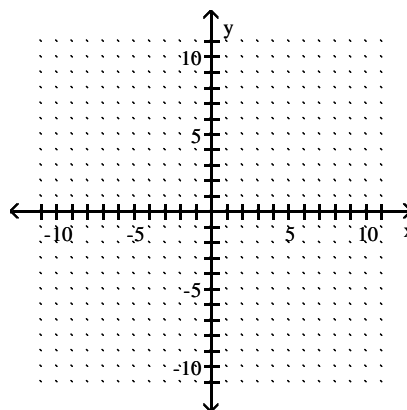

Graph the function by hand. Then use a graphing calculator to verify your graph. Find the domain and range of the function.

56) $f(x) = -2(8)^x$

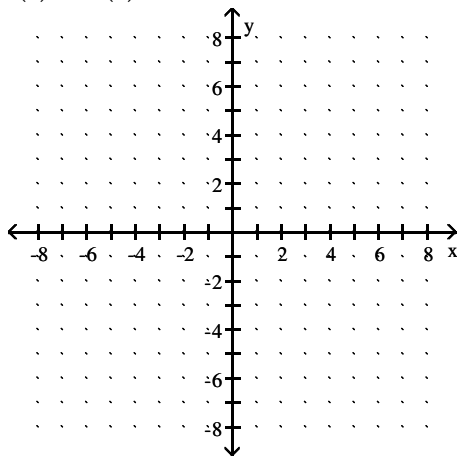

58) $f(x) = 8\left(\frac{1}{6}\right)^x$

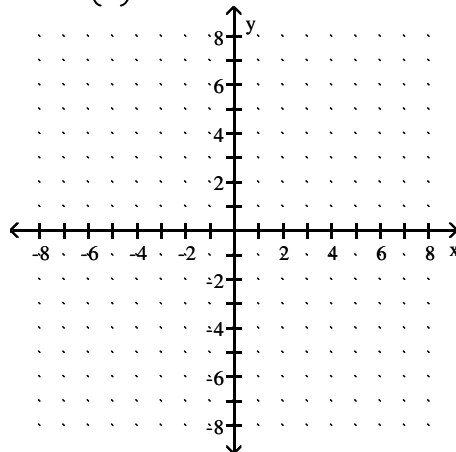

57) $f(x) = 5(6)^x$

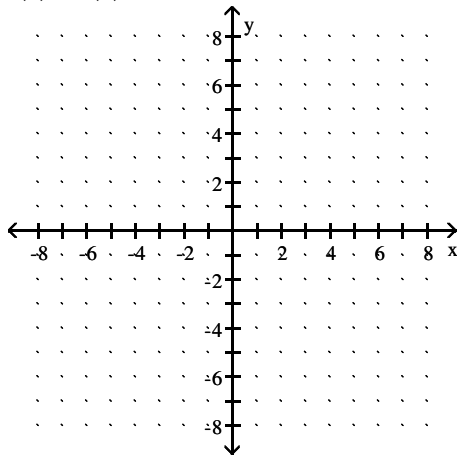

A graph of a function of the form $y = ab^x$ is given. What can you conclude about the constants a and b ?

59)

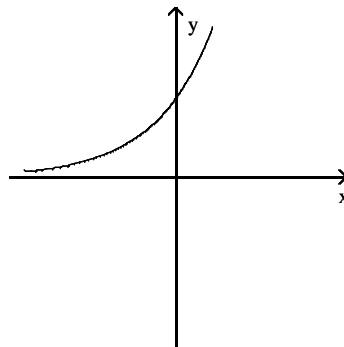

60)

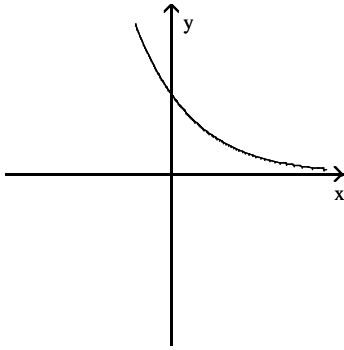

Use the graph to find the requested value.

63) Find x where $f(x) = -4$.

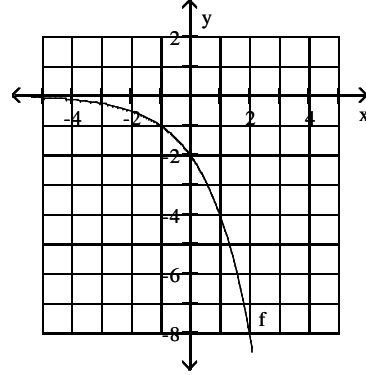

61)

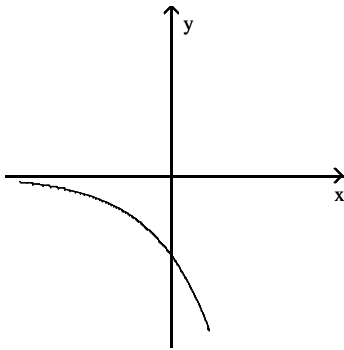

64) Find $f(-1)$.

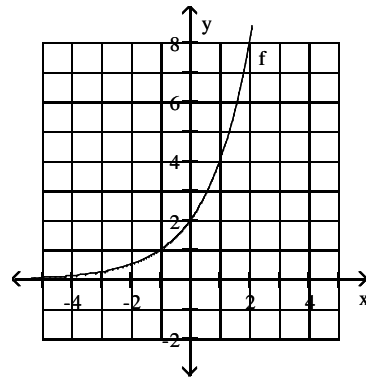

Input-output pairs of four exponential functions are listed in the table. Complete the table.

62)

x	$f(x)$	$g(x)$	$h(x)$	$k(x)$
0	4	162	3	1200
1	8	54	9	600
2	16	18		
3	32			
4				

65) Find $f(-1)$.

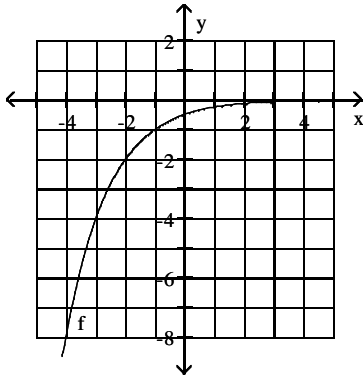

68) $y = -4\left(\frac{5}{7}\right)^x$

69) $y = -3\left(\frac{4}{9}\right)^x$

66) Find x where $f(x) = -1$.

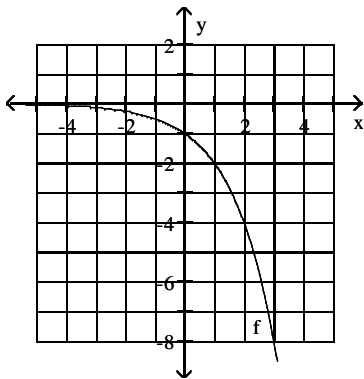

70) $y = 9\left(\frac{3}{2}\right)^x$

Find all real-number solutions. Round your answer to the second decimal place, if necessary.

71) $b^2 = 36$

Find the x- and y-intercepts for the function.

67) $y = 3\left(\frac{1}{2}\right)^x$

72) $b^4 = 256$

73) $2.7b^3 - 86.3 = 258.9$

Find an approximate equation $y = ab^x$ of the exponential curve that contains the given pair of points. Round the values of a and/or b to two decimal places, if necessary.

78) (0, 5.2) and (3, 91.7)

74) $\frac{1}{2}b^5 + \frac{7}{5} = \frac{7}{3}$

79) (2, 4) and (5, 57)

75) $\frac{3}{4}b^4 + \frac{8}{9} = \frac{9}{7}$

80) (2, 7) and (5, 69)

76) $\frac{b^7}{b^3} = 625$

81) (7, 16.7) and (12, 110.3)

77) $\frac{b^7}{b^4} = \frac{95}{4}$

82) (7, 14.3) and (12, 110.3)

83) (7, 14.3) and (12, 89.1)

Solve the system.

84) $y = 2(8)^x, y = 2\left(\frac{1}{3}\right)^x$

85) $y = 2(3)^x, y = 2\left(\frac{1}{9}\right)^x$

86) $y = 2(7)^x, y = 2\left(\frac{1}{8}\right)^x$

Solve the problem.

87) Two bacteria are placed in a petri dish. The population will triple every day. How many bacteria are in the dish four days after the two bacteria are placed in the dish?

88) Four bacteria are placed in a petri dish. The population will triple every day. How many bacteria are in the dish seven days after the four bacteria are placed in the dish?

89) Austin invested \$12,000 in an account at 6% compounded annually. Find the amount in Austin's account after a period of 2 years.

90) Suppose that 4725 units of a new product were sold in 2003. Each year after 2003, sales of the product were half the previous year's sales. Let $g(t)$ be the sales of units of the product in the year that is t years since 2003. Find an equation of g .

91) A particular new car is worth \$19,608. With each passing year, the value of the car will be 0.84 times its value the previous year. To the nearest dollar, what will the car be worth in 3 years?

92) The half-life of aspirin in a person's bloodstream is about 15 minutes. If a person's bloodstream contains 256 milligrams of aspirin, how much of that aspirin will remain after 105 minutes?

Answer Key

Testname: EXAM 1 PREPARATION CH 2, 3, & 4 V01

- 1) No
- 2) Yes
- 3) function
- 4) function
- 5) not a function
- 6) not a function
- 7) not a function
- 8) not a function
- 9) -10
- 10) 11
- 11) -3.6
- 12) 4.2
- 13) -5.4
- 14) 6.2
- 15) $f(m) = 0.05m + 4.95$
- 16) $f(m) = 0.07m + 5.95$
- 17) 3600.00
- 18) -1296
- 19) $-\frac{1}{9}$
- 20) $\frac{1}{4}$
- 21) 9
- 22) 81
- 23) x^5
- 24) x^{15}
- 25) $\frac{x^2}{y^4}$
- 26) $-12p^6$
- 27) $\frac{-15x^2}{y^3}$
- 28) $\frac{125}{7}x^5$
- 29) $\frac{x^{24}z^{18}}{64y^{27}}$
- 30) $4a^3b^5$
- 31) $\frac{x^3}{27y^4}$
- 32) $\frac{3z^8}{x^6}$
- 33) $\frac{x^6y^9}{27}$
- 34) 128
- 35) $125(5^n)$
- 36) 3,660,000

Answer Key

Testname: EXAM 1 PREPARATION CH 2, 3, & 4 V01

37) 3,150,000

38) 0.00009629

39) 0.00009919

40) 6.972×10^3

41) 5.111×10^{-5}

42) x

43) $\frac{1}{x^{31/30}}$

44) $\frac{1}{x}$

45) $x^{1/6}$

46) $8x^{5/12}$

47) bc

48) $64x^{1/7}$

49) $\frac{x^{3/2}}{y^{17/8}}$

50) $\frac{3c^{19/7}}{4b^{50/3}}$

51) $2y^{4/3}$

52)

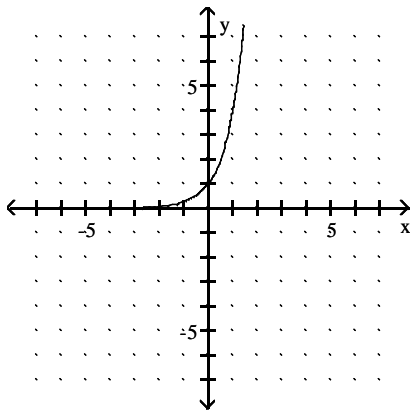

53)

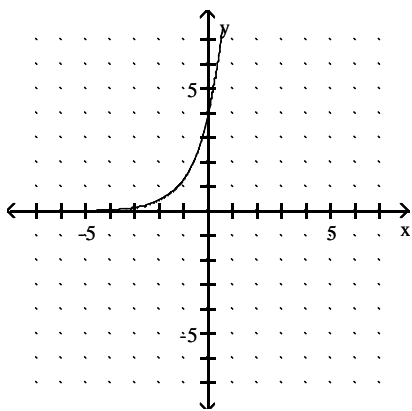

Answer Key

Testname: EXAM 1 PREPARATION CH 2, 3, & 4 V01

54)

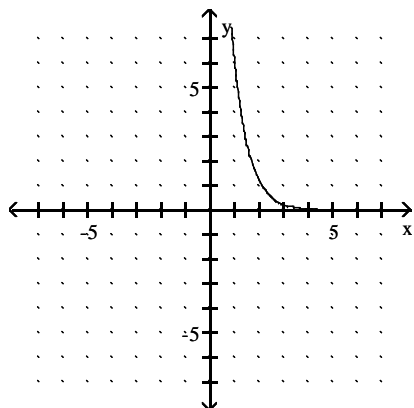

55)

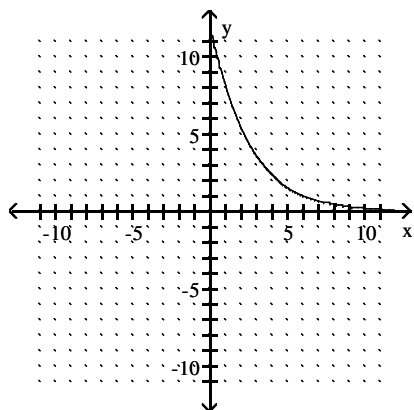

56) domain: all real numbers;

range: $y < 0$

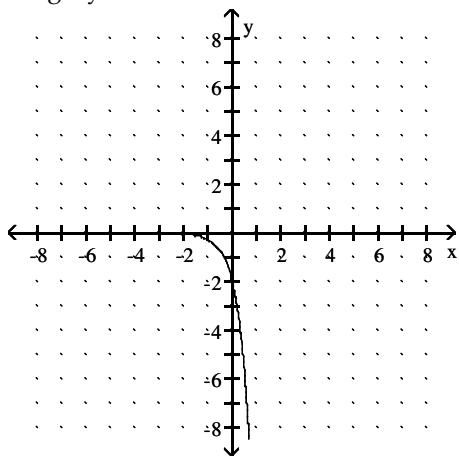

Answer Key

Testname: EXAM 1 PREPARATION CH 2, 3, & 4 V01

57) domain: all real numbers;
range: $y > 0$

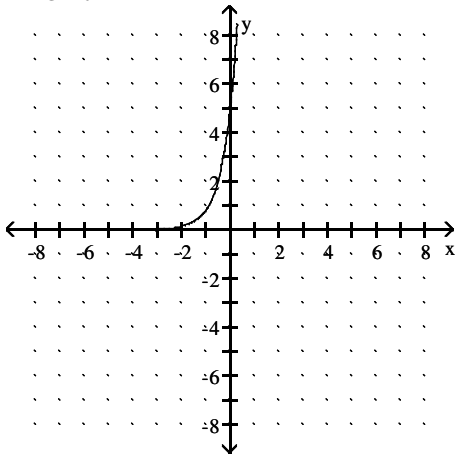

58) domain: all real numbers;
range: $y > 0$

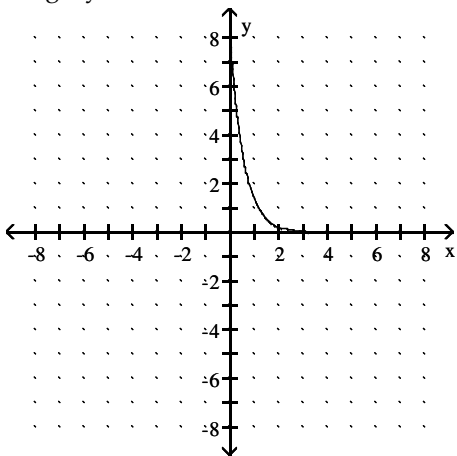

59) $a > 0$, $b > 1$

60) $a > 0$, $0 < b < 1$

61) $a < 0$, $b > 1$

62)

x	f(x)	g(x)	h(x)	k(x)
0	4	162	3	1200
1	8	54	9	600
2	16	18	27	300
3	32	6	81	150
4	64	2	243	75

63) 1

64) 1

65) -1

66) 0

67) no x-intercept; y-intercept is (0, 3)

68) no x-intercept; y-intercept is (0, -4)

69) no x-intercept; y-intercept is (0, -3)

70) no x-intercept; y-intercept is (0, 9)

71) ± 6

Answer Key

Testname: EXAM 1 PREPARATION CH 2, 3, & 4 V01

72) ± 4

73) 5.04

74) 1.13

75) ± 0.85

76) ± 5

77) 2.87

78) $y = 5.2(2.60)^x$

79) $y = 0.68(2.42)^x$

80) $y = 1.52(2.14)^x$

81) $y = 1.19(1.46)^x$

82) $y = 0.82(1.50)^x$

83) $y = 1.10(1.44)^x$

84) (0, 2)

85) (0, 2)

86) (0, 2)

87) 162

88) 8748

89) \$13,483.20

90) $g(t) = 4725(0.5)^t$

91) \$11,622

92) 2 mg